

Sept. 29, 1953

R. E. MOORE ET AL
ACCUMULATOR FEATHERING SYSTEM FOR VARIABLE
PITCH PROPELLER CONTROL

2,653,669

Filed Nov. 8, 1947

2 Sheets-Sheet 1

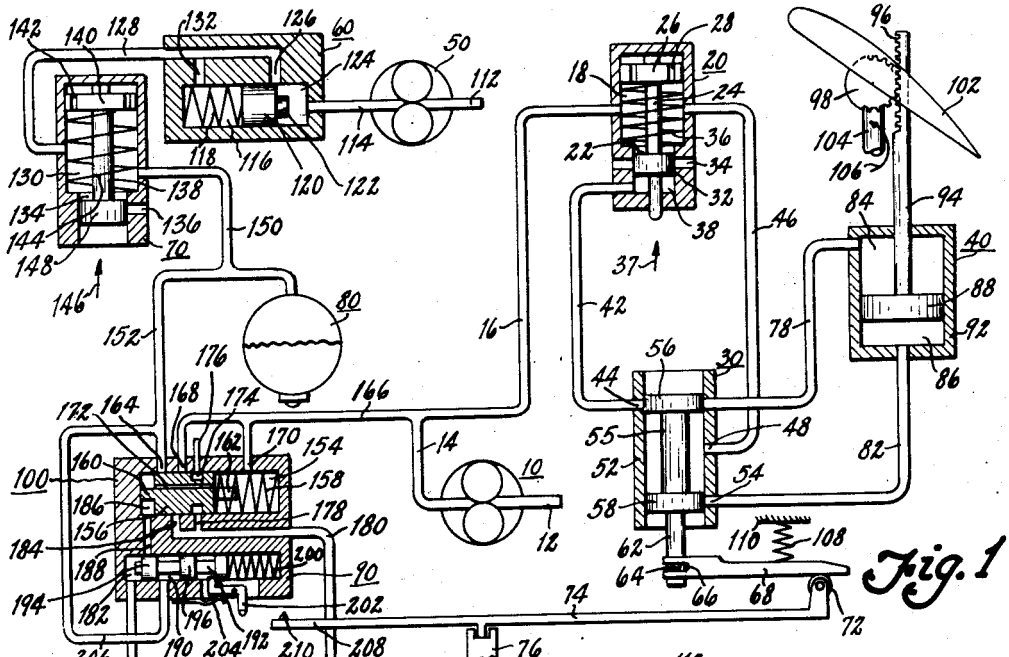

Fig. 1

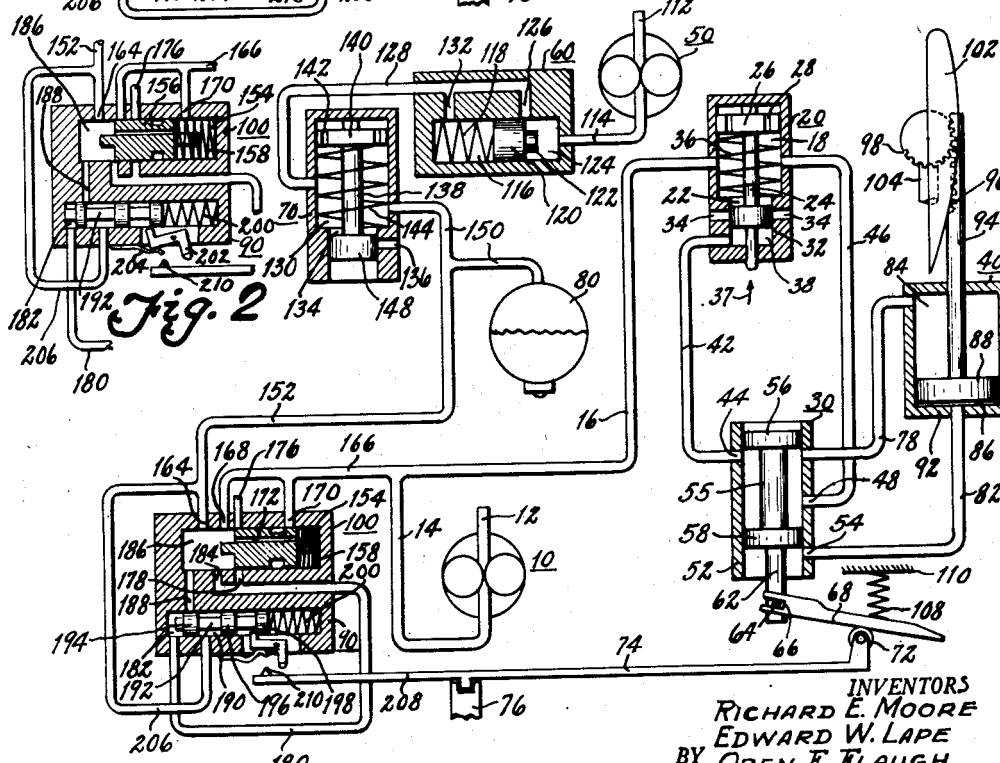

Fig. 2

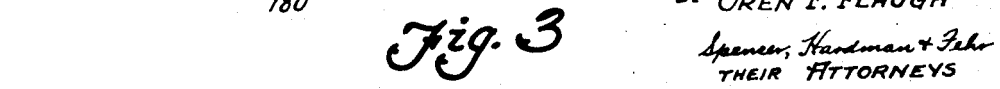

Fig. 3

INVENTORS
RICHARD E. MOORE
EDWARD W. LAPE
BY OREN F. FLAUGH

Spencer, Hardman & Fehr
THEIR ATTORNEYS

Sept. 29, 1953

R. E. MOORE ET AL
ACCUMULATOR FEATHERING SYSTEM FOR VARIABLE
PITCH PROPELLER CONTROL

2,653,669

Filed Nov. 8, 1947

2 Sheets-Sheet 2

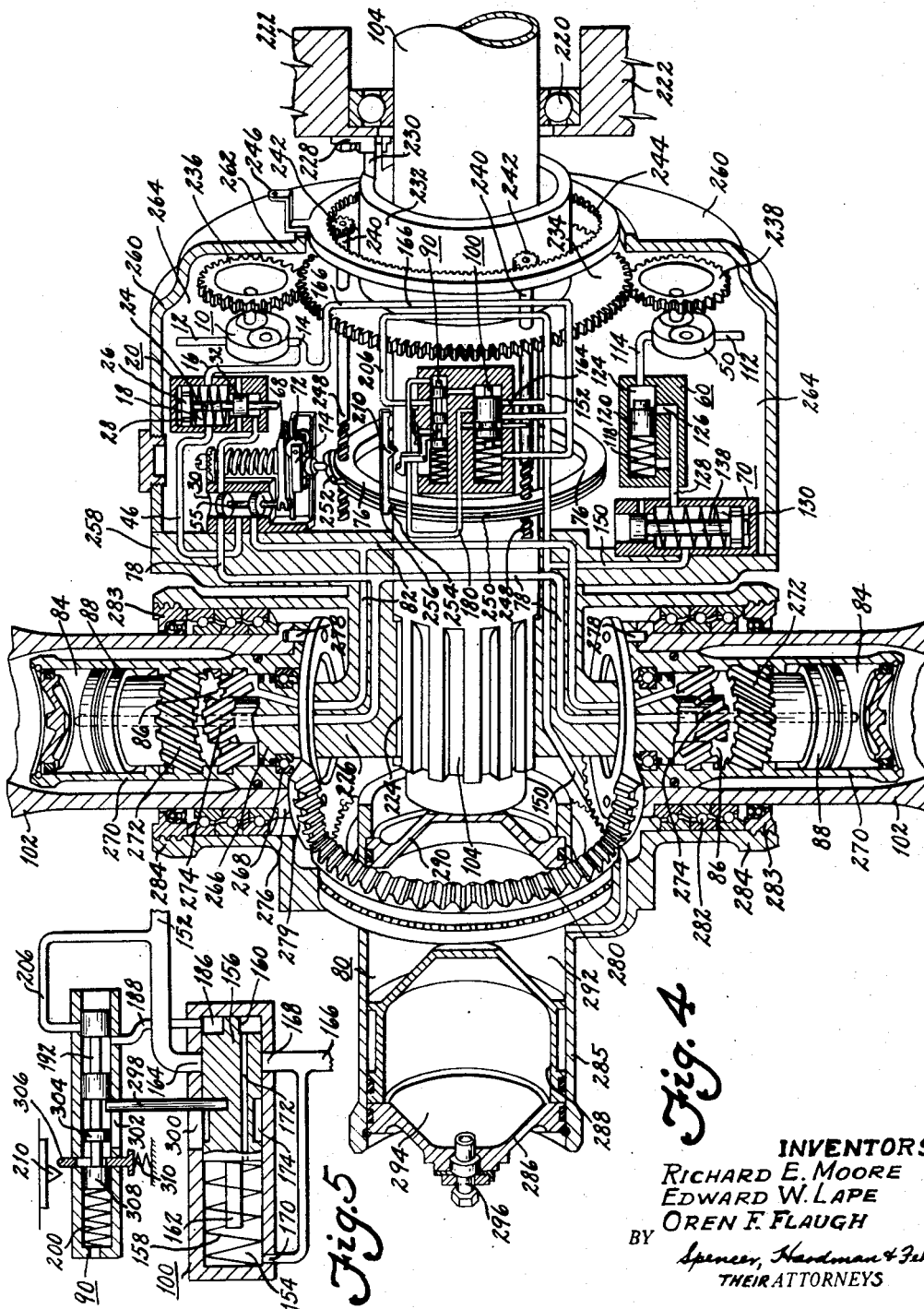

Fig. 4

Fig. 5

INVENTORS
 RICHARD E. MOORE
 EDWARD W. LAPE
 OREN F. FLAUGH
 BY *Spencer, Hardman & Felt*
 THEIR ATTORNEYS

UNITED STATES PATENT OFFICE

2,653,669

ACCUMULATOR FEATHERING SYSTEM FOR
VARIABLE PITCH PROPELLER CONTROL

Richard E. Moore, Dayton, Edward W. Lape,
Piqua, and Oren F. Flaugh, West Milton, Ohio,
assignors to General Motors Corporation, De-
troit, Mich., a corporation of Delaware

Application November 8, 1947, Serial No. 784,788

15 Claims. (Cl. 170—160.21)

1

This invention relates to fluid pressure mechanism for control of propeller pitch, and has for a principal object to provide an accumulator feathering system that will not interfere with a variable pressure system for control of blade pitch whether the accumulator system is being charged or discharged.

A further object of the invention is to provide a system that will not take all the available flow from the pump or pumps when a pitch change is being made.

A further object is to provide a system for filling an accumulator from the output of an auxiliary pump guarded as to its maximum limit by a pressure control valve.

A further object of the invention is to provide a feathering control system with a control valve unit of the flow responsive type that may be set into motion incident to a manually controlled pilot valve, which becomes reset during the cycling of the flow responsive valve in connecting the accumulator to the fluid pressure line.

A further object of the invention is to provide a hydraulic system of control for blade pitch shifting that incorporates a dual fluid pressure source, one of which is specific to governed pitch shift and the other of which is supplementary for use in feathering and unfeathering.

Further objects and advantages of the present invention will be apparent from the following description, reference being had to the accompanying drawings, wherein a preferred embodiment of the present invention is clearly shown.

In the drawings:

Fig. 1 is a fluid circuit diagram connecting the elements of the control system, showing the relation of parts conditioned for governed positive pitch control, and accumulator filling.

Fig. 2 is a fragmentary detail showing the specific stem in the movement of the flow control valve in connecting the accumulator to the pressure feed line.

Fig. 3 is a circuit diagram of the entire circuit illustrating the relation of parts when the blades of the propeller are being feathered.

Fig. 4 is a schematic view of a propeller structure showing an adaptation of the circuit diagram of Fig. 1 to effect the specified control.

Fig. 5 is a view of a modified form of feathering control valve.

Making general reference to the drawings, 10 refers to a system pump that is driven by propeller rotation and feeds fluid under pressure to a variable pressure control valve 20 that regulates the potential of pressure delivered to a governor

2

or distributor valve 30 which responds to a deviation from a balance of centrifugal force and spring pressure to apply the fluid pressure to one side or the other of a double acting servomotor 40, that in turn shifts the propeller blades in either a pitch increasing or pitch decreasing sense as determined by the operating conditions selected. An accumulator fill or charging pump 50 delivers to a check valve 60 that determines the flow of pressure developed by the pump 50 to the accumulator 80, an accumulator pressure control valve 70 limiting the maximum charge to be stored in the accumulator 80. Dumping of the accumulator 80 is controlled by a flow responsive valve 100 under control of a resettable trip valve 90 selectively tripped by a manual control that effects selection of the speed level at which the governor valve 30 will control. The governing pitch circuit and the accumulator supply circuit are so much independent that neither interferes with the other, but the feathering control valve is adapted to connect the accumulator supply circuit to the governing pitch circuit when needed for effecting the feathering or unfeathering function.

More specifically, the pump 10 has an intake at 12 from a reservoir and a delivery or output passage 14 that empties into a pressure line 16 connecting with a pressure chamber 18 of the variable pressure control valve 20. The chamber 18 has a reduced extension 22, and there is a valve plunger 24 traversing the bore of the unit, which plunger has a damping head 26 with bleed passages 28, and a valving land 32 designed to cooperate with blowoff ports 34 open to the reservoir. Within the chamber 18 there is a spring 36 bearing against the head 26 to assist centrifugal force (toward the top of the drawing as indicated by arrow 37) in closing the ports 34 by the land 32. A biasing chamber 38 below the land 32 has a fluid connection by the tube 42 with an increase pitch port 44 of the governor valve 30, while a passage 46 constituting an extension of the pressure line 16 leads from the pressure chamber 18 to a waist or supply port 48 of the governor valve 30.

The governor valve 30 in its essence includes a sleeve 52 providing the ports 44 and 48, and has an additional port 54 constituting a decrease pitch port, the bore of the sleeve 52 being traversed by an axially movable valve plunger 55 having lands 56 and 58 spaced to cover the ports 44 and 54 when the valve plunger 55 is in the mid-position or in equilibrium. An extension 62 of the valve plunger 55 carries a cross pin 64 that

engages in an end slot 66 of a lever 68 whose remote end rests upon a movable fulcrum roller 72 mounted on a carriage 74 shiftable by means of a control ring 76, later to be described. Connecting with the increase pitch port 44 there is a passage 78, while connecting with the decrease pitch port 54 there is a passage 82, both of which lead to the servo 40, the passage 78 opening into a chamber 84 and the passage 82 opening into a chamber 86, one on either side of a piston 88 longitudinally movable within the casing 92 of the servo 40, and having a stem 94 providing a rack 96 engaging a gear 98 attached to the root end of a blade 102 rotatable by a hub and shaft 104 in the direction suggested by the arrow 106. The lever 68 is maintained in contact with the fulcrum 72 by means of a spring 108 seated against an abutment 110 and engaging the lever 68 midway its length, which in the relation of parts shown in Fig. 1 tends to move the valve plunger 55 radially inward against centrifugal force tending to move the plunger 55 radially outward. The position of the fulcrum 72 along the length of the lever 68 determines the speed level at which the governor valve 30 will operate to control the pitch for constant speed. Means, as will presently be described, are provided for setting the fulcrum 72 along the length of the lever 68 which fulcrum, of course, may be situated at practically any point to the right or to the left of the line of spring pressure.

The accumulator supply or feathering circuit is fed by the pump 50 which has an intake 112 from the reservoir and an outlet 114 opening into the check valve unit 60 which comprises a pressure loading chamber 116 housing a spring 118 seated against a piston valve 120 having a stem 122 that defines a chamber 124 into which the outlet 114 empties. Pressure from the outlet 114 tends to move the valve cylinder 120 toward the left compressing the spring 118 until it opens a port 126 leading to a passage 128 communicating with a pressure chamber 130 of the accumulator pressure control valve 70. This check valve 120 is pressure loaded because of a passage 132 connecting the chamber 116 to the left of the valve 120 with the passage 128. Hence, the pump 50 must overcome the resistance of the spring 118 and any pressure that is existent in the passage 128 before the chamber 124 can have communication with the passage 126.

The accumulator pressure control valve 70 is somewhat similar to the variable pressure control valve 20, since its chamber 130 has a reduced bore 134 with a lateral opening 136 leading back to the reservoir. A valve plunger 138 is longitudinally movable of the bore 130, 134 and has a damping head 140 with bleed passages 142, the plunger head 140 being engaged by a spring 144 that normally assists centrifugal force which is, in an installation, directed radially outward as indicated by the arrow 146. At the lower end of the plunger, a land 148 moves along the reduced bore 134 and cooperates with the port 136 to control the high limit of pressure potential existing in the passage 128 and the passage 150 that leads from the chamber 130 to the accumulator 80. The pump 50 delivers fluid under pressure into the chamber 124 whenever the propeller is rotating, and the pressure of the passage 128 is also existent within the chamber 130 and the passage 150 leading to the accumulator. If the potential of that pressure tends to mount to a value in excess of that determined for the accumulator 80, its effect will

be felt by the area of the land 148 which will tend to move the valve plunger 138 in opposition to the combined forces of centrifugal force and the spring 144 acting radially outward. Hence the valve plunger will move far enough radially inward to sufficiently open the port 136, that the excess of pressure in the accumulator will be relieved.

From the foregoing it will be observed that the accumulator is being charged while the propeller is rotating, but that the accumulator charging offers no interference with the pitch governing function of the governor 30 and the servomotor 40. For purposes of connecting the accumulator pressure with the pressure line 16, a branch 152 from the accumulator filling passage 150 leads to the flow control valve 100 that embraces a chamber 154 housing a cylindrical member 156 urged to one extreme position by a spring 158 which member normally stops fluid flow from the accumulator 80 through the passage 152 into the chamber 154. The cylindrical member 156 has a stem 160 at one end and a stem 162 at the other end which permits the cylindrical member 156 to move within the chamber 154, but always leaves an end portion of the cylindrical member exposed to fluid pressure at either end of the chamber 154. The passage 152 opens into the chamber 154 at 164 where it is normally blocked by the cylindrical surface of the member 156. An extension 166 from the pressure line 16 opens at two points 168 and 170 into the chamber 154. The port 168 is normally closed by the cylindrical member 156 in the illustrated spring urged position of Fig. 1, and the port 170, which may be called a relief port opens into the chamber at the right hand side of the member 156, and a bleed passage 172 connects opposite ends of the cylindrical member for purposes presently to be described. The cylindrical member 156 also embraces an annular groove 174 that communicates with a drain passage 176 and with a drillway 178 aligned therewith, but which opens into a passage 180 extending from a reset chamber 102 of the trip valve 90. The passage 180 has a second port 184 that opens into the chamber 100 of the flow responsive valve, but which is normally closed while the cylindrical member 156 is in its spring urged position, the drillway 178 and drain passage 176 at that time being in communication with the annular groove 174 for the purpose of draining or relieving the reset passage 182 through the passage 130.

The annular passage about the stem 160 of the cylindrical member 156 may be termed an actuating chamber 186 since it has a passage 188 leading into a bore 190 forming an extension of the reset passage 182. Longitudinally movable within the bore 190 is a valve plunger 192 that provides a valve land 194, a guide land 196, and a latch land 198, the latter of which is engaged by a spring 200 confined within the bore 190 and normally urging the plunger 192 toward the left of the figure. A bell crank latch 202 is urged by a spring 204 into the path of the latch land 198 which maintains the plunger 192 in such a position that the land 194 covers the opening into passage 188. In that position a passage 206 opening into the bore 190 from between the valve land 194 and the guide land 196 leads back to the tubular extension 152 from the accumulator.

When it is desired to feather the propeller, the carriage 74 is actuated from the cockpit of the

5

craft such as to move the fulcrum 72 from the position shown in Fig. 1 to the position of the fulcrum shown in Fig. 3. In so doing an extension 208 of the carriage 74 causes a cam 210 to actuate the bell crank latch 202 which then withdraws from in front of the latch land 198 and allows the plunger 192 to move toward the left to the position illustrated in Fig. 2. In that position, the plunger 192 allows fluid communication between the passage 206 and the passage 188 such that accumulator pressure then flows through 152, 206 around the stem or waist of the plunger 192 and through the passage 188 into the chamber 186. If the potential of the pressure admitted in chamber 186 is greater than the aggregate of the line pressure in chamber 154 plus the assistance of the spring 158, then the cylindrical member 156 will move toward the right hand position of Fig. 2, which first opens the port 164 to the actuating chamber 186, then blocks the drain passage 176, and then opens passage 184 to the expanding chamber 186, and finally opens port 170 to the chamber 186. During this movement, as soon as the valve member 156 opens the port 164 then the accumulator pressure is applied to the chamber 186 directly through the port 164, which is of less resistance to flow than that through passage 206, 190 and 188. The valve member 156 is consequently moved with a greater force toward the right hand, first closing the drain 176 from the chamber 182 and thence rapidly opening the passage 180 through 184 to the actuating chamber 186 such that the accumulator pressure may be effective through 180 to the chamber 182 for resetting the plunger 192 in the latched position. The plunger 156 then is free to move further to the right connecting the ports 164 and 168 such that there is direct communication between the accumulator 80 and the pressure line 16 through the passage 152, actuating chamber 186 and extension 166.

Thus the flow control valve 100 cycles on tripping of the pilot valve 90 to block the drain from chamber 182, applies accumulator pressure to the chamber 182 for resetting the trip valve, and finally dumps the accumulator pressure into the pressure line 16. The governing pitch system including the pressure line 16, the variable pressure control valve 20 and the governor valve 30 has already been conditioned for properly applying the added pressure coming through the branch 166 to the servomotor 40 for feathering of the blades as shown in Fig. 3. When the fulcrum 72 is moved to the feathering position that places the pivotal point for the lever 68 at a point under the lever 68, between the pivotal connection 64 of the valve plunger 55 and the line of spring pressure 198. In that position, the spring force and centrifugal force are operating in adding relation and so disturb the equilibrium between those forces that the valve plunger 55 no longer effects governed control but moves radially outward to provide a wide and unrestricted opening between the pressure supply port 48 and the pitch increase ports 44. One of these ports 44 connects through passage 78 with the increased pitch chamber 84 of the servomotor 40, and the other passage 42 connecting with the port 44 leads back to the biasing chamber 38 of the variable pressure control valve 20 and operates to assist centrifugal force and spring force operating to move the valve plunger radially outward such that the land 32 blocks escape of pressure fluid from the drain port 34. Hence, all of the pressure potential now existent in the pressure line

6

16 passes through the chamber 18 of the variable pressure control valve and through the ports 48 and 44 of the governor valve to the increased pitch chamber 84 of the servo. The decreased pitch port 86 being open through drain 82 and port 54, permits the piston 88 to move to the extreme limit and the rod 94 acting through the rack and gear rotate the blade 102 in an increasing pitch sense so as to be edge on into the wind. As soon as the blade 102 reaches the feather position, there is no further flow into and out of the chamber 186 and the pressure becomes equalized at both ends of the cylindrical member 156 by reason of the longitudinal bleed 172. The spring 158 therefore forces the cylindrical member 156 toward the left which reacts upon the ports opening into the bore 154 in the reverse order, first closing the port 168, thence closing 184 and opening drain 170, with a final closing of port 164, whereupon the cylindrical member 156 assumes it in spring-urged position. The remaining pressure potential of the accumulator is thereby blocked against entering the flow control valve and is concerned for a subsequent application to the servo for the unfeathering function.

For the unfeathering function, the movable fulcrum 72 is moved to the right toward the end of the lever 68 which again causes the cam 210 to trip the bell crank lever 202. That releases the pilot valve which is then spring-urged toward the left, and an identical sequence of operations transpire to open the accumulator to the pressure line 16 and close it again with an attendant resetting of the trip valve. It should be observed that when the feathering function is called for, that one of two conditions may obtain. One condition is that in which the propeller mechanism is at rest or it is not rotating, while the second condition is that the propeller is rotating. Under the condition of non-rotating propeller, the accumulator 80 must supply all of the pressure potential required for moving the blades to the feathered condition illustrated in Fig. 3. When feathering is called for while the propeller is rotating, both pumps 10 and 50 will be operating. The pump 10 may provide sufficient fluid under pressure in the line 16 to at least start the feathering function. The output of pump 10 may be sufficient to accomplish a major portion of the feathering function, since the radially outward movement of the valve 55 to the wide open position of the increase pitch port 44 applies the full force and effect of fluid pressure in the pressure line 16 and 46 through one of the ports 44 and the passage 42 to the biasing chamber 38 of the variable pressure control valve. Pressure applied to the biasing chamber 38 assists centrifugal force and the spring force acting on the plunger 24 to completely close the exhaust ports 34. That applies all of the pressure in the line 16 and 46 to the waist of the plunger 55 and through the ports 44 to the chamber 84 of the servo. Of course that same pressure follows the line 166 to the relief side of the flow control valve 100 and is there applicable through the port 170. Thus, more resistance is offered to the movement of cylindrical member 156 and it does not start to move until the pressure in line 16 and 166 assisted by the spring 158 is somewhat below the potential of the pressure in passage 152. In other words, the cylindrical member 156 does not move to connect the accumulator pressure from 152 to the branch 166 until there is sufficient pressure differential on opposite ends of the member 156

to permit its movement toward the right hand in the figure.

In all cases of unfeathering, the pressure first applied to the servo is accomplished while the propeller is not rotating and thus requires sufficient application of energy to move the blades from an edge on position such as shown in Fig. 3 to an angular position somewhat comparable to that shown in Fig. 1. There are also two possible conditions under which unfeathering may be applied to the propeller. One is that in which the craft is on the ground with the propeller not rotating. The other condition is that in which the craft is in the air but is not rotating. In the case of feathering while the craft is on the ground and the propeller not rotating, the unfeathering is accomplished wholly by the pressure potential stored in the accumulator. In the case of unfeathering while the craft is in flight, the accumulator pressure is applied to the pressure line for starting the unfeathering function, the completion being effected by the unwindmilling of the propeller which sets the pumps into operation. Rotation of the pumps while the propeller is windmilling will deliver fluid under pressure sufficient to give some assistance to the pressure potential from the accumulator. The fluid pressure delivered by the accumulator or by the accumulator supplemented by the pumps to lines 166, 16 and 46 to the governor valve where it is applied to port 54, passage 82 to the decrease pitch chamber 86 of the servo. That application causes such rotation of the blade 102 as to take up an angular position where the air stream flowing through the propeller disc will cause windmilling of the propeller. As soon as the propeller begins to rotate the pumps 10 and 50 are rotated and the output of both of them are added to the pressure line such that the potential of the accumulator 80 is assisted in shifting the blade pitch out feather position into the normal working position. Windmilling of the propeller soon manifests in starting of the engine after which the pressures at opposite ends of the flow control valve 100 are so apportioned that the cylindrical member 156 returns under the aid of spring 158 to interrupt the connection of the accumulator line 152 and the pressure line 16.

In a physical embodiment of the invention all of the elements of the control apparatus and the fluid circuit connections are carried by the rotating structure of the propeller, somewhat as exemplified by the view of Fig. 4, where the shaft 104 is supported by bearing means 220 anchored in the framework 222 of the craft or engine support. It is understood that the shaft 104 is to be driven by the engine, not shown, which shaft by reason of its splined or equivalent driving connection at 224 with the hub 226 effects rotation of the propeller, and consequently all of the control apparatus.

Fixed to the framework 222 there is a clip or other abutment member 228 that engages a lug 230 of an adapter sleeve 232 embracing the shaft 104. The sleeve 232 therefore stands still with the framework while the propeller rotates. A toothed flange 234 extending radially from the sleeve 232 is engaged by pinions 236 and 238 of the pumps 10 and 50, in such manner that rotation of the propeller causes the pinions 236 and 238 to roll upon the toothed flange 234 thereby giving driving force to the pumps.

Journaled in the toothed flange 234 there are a plurality of control screws 240 each of which

carries a pinion 242 meshing with an internal toothed ring 244 providing a lever 246 which may be linked with a rod or cable extending to the cockpit of the aircraft. The ends of the control screws 240 are provided with a high lead screw 248 each of which threads through the control ring 76 referred to in connection with the description of circuit diagrams shown in Figs. 1, 2 and 3. It will be observed that oscillation of the lever 246 causes substantially equal rotation of the pinions 242 and incidentally rotation of the shafts 240 which by reason of the threaded connection to the control ring 76 effects its axial movement along the shaft 104. The ring 76 provides a peripheral groove 250 within which are disposed in sliding engagement a shoe member 252 provided by the carriage 74 for the governor valve 30, and also a shoe 254 of a bar member 256 for actuating the cam 210. Attached to the rear of the hub 226 there is a plate member 258 embedding certain of the control passages and forming a support for certain of the elements of the control apparatus somewhat as is disclosed and claimed in the patent to Blanchard et al., No. 2,307,102. Attached to the base plate 258 there is a cover member 260 that encloses all of the control apparatus and extends inwardly to the flange 262 to substantially enclose all of the adaptor assembly except the ring gear 244. Thus the annular chamber provided by the union of the plate 258, the cover 260, the flange 262 and the adaptor assembly 232 provide a reservoir 264 for containing the hydraulic fluid or medium upon which the control apparatus works to effect its blade shifting movements.

The hub has radially extending spindles or bosses 266 supporting a pilot bearing 268 about which is rotatable a fluid cylinder 270 housing the piston 88. Here the piston 88 provides a skirt portion with splines at 272 meshing with internal splines of the cylinder and with the exterior splines 274 of the spindle 266. Appropriate passages extend from the tubular elements 78 and 82 through the spindle and piston to communicate with the chambers 84 and 86. The cylinder 270 provides a flange 276 doweled at 278 to the root end of the blade 102 and supports a blade gear 279 meshing with a master gear 280. Appropriate stack bearings 282 and nut 283 retain the blade 102 within its respective socket 284. From this it will be seen that application of fluid pressure by the governor valve 30 to either one of the control passages 78 or 82 will exert a force in either of the chambers 84 or 86 and effect radial movement of the piston 88 lengthwise of the spindle and cylinder.

Since the skirt of the piston 88 is joined to the spindle and cylinder by helical splines it will be apparent that radial movement of the piston will effect rotation of the blade 102 and that all of the blades will rotate equally by reason of the same fluid pressure being applied to the servo of each blade and since all blades are coupled together in their rotative sense by the master gear 280.

The accumulator 80 comprises an axial extension 285 extending from the hub 226 which is closed at one end by a cap member 286 and houses a rigid piston 288 movable axially of the sleeve 285. A head member 290 closes the other end of the accumulator, and provides a chamber 292 between the piston 288 and head 290 to which the passage 150 is connected as has been heretofore described. The space within the cylinder 285 between the piston 288 and cap 286 provides

a loading chamber 294 which is charged with an inert gas through a filler valve 296.

In Fig. 4, the feathering control valve including the trip valve 90 and flow control valve 100 have been shown with the circuit connections described with respect to Figs. 1 and 3 and it should be apparent that oscillation of the lever 246 will effect such movement of the control ring 76 that the fulcrum 72 may be selectively positioned along the length of the lever 68 of the governor valve. Also it should be apparent that movement of the control ring 76 will actuate the member 256, and that if the control ring is moved far enough toward the left of the figure, that the cam member 210 will move the bell crank lever 202 to trip the valve 90 which results in the fluid passages and valves being so conditioned that fluid pressure in the chamber 292 will flow therefrom and finally reach the appropriate chambers of the servo within the blade for effecting the desired pitch change.

In the illustration of Fig. 4, the feathering control valve illustrated is that in which reset of the pilot valve is effected by applying pressure from the accumulator. In Fig. 5, a modification of the feathering control valve is shown, and in which the reset of the trip valve 90 is mechanically effected by movement of the flow control valve 100. In that embodiment a pin 298 anchored in the cylindrical member 156 is adapted to move along a slot 300 of the casing for the flow control valve and has its other end operating through a slot 302 in the casing of the pilot valve to be in the path of an actuating land 304 of the plunger 192. As the cylindrical member 156 moves toward the left in connecting the accumulator pressure with the pressure 166, the pin 298 engages the land 304 and returns the plunger 192 to the latched position as shown where a cross slide 306 is spring-urged into engagement with a retaining land 308. The latch member 306 has an aperture therethrough which allows the land 308 to pass through when the member 306 is moved by the cam member 210 to depress it against the spring 310. When the latch plate 306 is moved, the plunger 192 thence moves to the right under the urge of spring 200 so as to connect passages 188 and 206, thereby applying the accumulator pressure to the actuating chamber 186 for movement of the cylindrical member 156 toward the left until the ports 164 and 168 are connected.

While the embodiment of the present invention as herein disclosed, constitutes a preferred form, it is to be understood that other forms might be adopted, all coming within the scope of the claims which follow.

What is claimed is as follows:

1. A fluid pressure system for control of propeller pitch, comprising a double acting fluid servomotor for adjusting the propeller blades in governed pitch and feathering, a system pump providing a source of fluid pressure, a governor valve responding to domination of spring and centrifugal force effecting governed pitch by said servomotor, means for manually adjusting the valve establishing any one of a plurality of equilibrium conditions for said spring and centrifugal forces and for upsetting such equilibrium during feathering, a variable pressure control valve for the system controlling the pressure applied to the servomotor as needed for governing, and an independent source of fluid pressure for effecting feathering and unfeathering of said propeller and including a second pump and an accumulator with control means for connecting

the accumulator with the system pump upon predetermined movement of the upsetting means, said control means including a flow control valve normally spring-urged to block connection between the accumulator and the system pump, and a pressure reset valve releasable by said equilibrium upsetting means to apply accumulator pressure to the flow valve for connecting the accumulator with the system pump.

2. A fluid pressure system for control of propeller pitch throughout its full range of governed pitch and feathering pitch, the combination comprising, a hydraulic circuit including a variable pressure control valve and a distributor valve for effecting governed pitch for constant speed operation at any one of a plurality of selected speed levels, a pump charged accumulator and control valve means for controlling the connection of said accumulator with said hydraulic circuit, said control valve means including a flow valve exposed to said hydraulic circuit for normally blocking any fluid connection between said circuit and the accumulator, and a trip valve for applying accumulator pressure to the flow valve in opposition to the hydraulic circuit for unblocking the connection between the accumulator and the hydraulic circuit during feathering and unfeathering pitch control.

3. A fluid pressure system for control of propeller pitch throughout its full range of governed pitch and feathering pitch, the combination comprising, a hydraulic circuit including a variable pressure control valve and a distributor valve for effecting governed pitch for constant speed operation at any one of a plurality of selected speed levels, a pump charged accumulator and control valve means for controlling the connection of said accumulator with said hydraulic circuit, said pump charged accumulator including a pressure loaded check valve and an accumulator pressure control valve operable to maintain the accumulator charge between predetermined limits having a maximum potential variable in response to propeller speed, said control valve means including a flow valve and a trip valve for exposing the flow valve to the opposing pressures of the accumulator and the hydraulic circuit, means controlled by said flow valve operating to connect the accumulator to the hydraulic circuit only when the potential of the accumulator pressure dominates the pressure of the hydraulic circuit under control of the variable pressure control valve by a predetermined differential.

4. In a hydraulic circuit for feathering and unfeathering propeller blades, and having servo motor and fluid circuit for shifting the propeller blades, the combination comprising an accumulator, a pump for charging the accumulator, a pressure control valve responding to centrifugal force, spring force and pressure in the accumulator for effecting a limited maximum pressure in said accumulator, and a control valve for connecting and disconnecting the accumulator to the said fluid circuit, said control valve including a flow valve subject to the pressure of said fluid circuit, and means for applying an opposing force from the accumulator to move the flow valve against the pressure of and made active by said fluid circuit, said flow valve when so moved and operating to return the applying means to a retracted position for repeating the application of accumulator pressure to said flow valve.

5. A control for hydraulically actuated con-

trollable pitch propellers providing for constant speed operation and feathering operation, comprising in combination, a pump providing a source of fluid pressure, automatically operating speed responsive means for controlling the propeller pitch to constant speed, and including a fluid pressure line connecting with the source, and a distributing valve for selectively shifting the propeller blades, an independent source of fluid pressure and pressure storing means selectively connected with said pressure line, a controllable valve unit for controlling the connection of the independent source and pressure line and including a spring pressed plunger having one face exposed to the fluid pressure line and an opposing face exposable to said independent source, a reset valve adapted to be set in a position to interrupt independent source fluid pressure application to the said plunger, means for releasing the setting of the reset valve for applying the independent source fluid pressure to the opposing face of said plunger, and latch means operable upon movement of said plunger in response to application of said independent source of fluid pressure for resetting the reset valve.

6. A control for a hydraulically actuated controllable pitch propeller providing for constant speed operation and feathering operation, comprising in combination, a source of fluid pressure automatically operating speed responsive means for controlling the propeller pitch to constant speed, and including a fluid pressure line connecting with the source, and a distributing valve for selectively shifting the propeller blades, an independent source of fluid pressure and pressure storing means selectively connected with said pressure line, a controllable valve unit for controlling the connection of the independent source and pressure line and including a spring pressed plunger having one face exposed to the fluid pressure line and an opposing face exposable to said independent source, a pressure reset valve adapted to be retained releasably in a position to interrupt independent source pressure from the pressure storing means reaching the opposing face of said plunger, means operable upon selecting the feathering operation for tripping the reset valve to apply said independent pressure to the plunger for moving the plunger to a position connecting the pressure storing means with the said pressure line, and passage means having a port opened while the plunger is moving under the influence of said independent pressure source for applying stored pressure to the reset valve for resetting it in the retained position.

7. In a fluid pressure system of control for propeller blade pitch, a variable pressure system including a pressure source, a fluid servomotor and distributor valve for shifting the pitch of the blades in either an increasing sense or a decreasing sense, an accumulator feathering system with means connecting to said variable pressure system for feathering and unfeathering the propeller blades without interfering with the variable pressure system, said feathering system including a pressure storing means, independent pressure developing means for charging said pressure storing means while the propeller is rotating but without affecting the variable pressure system in its change pitch requirements, a feathering control means for controlling the connection between the variable pressure system and the accumulator feathering system, said control means including a valve spring-urged to inter-

rupt said connection, a pilot valve for applying the charge of said pressure storing means to the spring urged valve for opening said connection, means for retaining the pilot valve in a position to interrupt flow of accumulator pressure to the variable pressure system, and fluid pressure means made operable by movement of said spring-urged valve to the connecting position for moving the pilot valve from a position where the accumulator feathering system is connected to the variable pressure system to the said retaining position of said pilot valve.

8. In a fluid pressure system of control for propeller blade pitch, a variable pressure system including a pressure source, a fluid servomotor and distributor valve for shifting the pitch of the blades in either an increasing sense or a decreasing sense, an accumulator feathering system with means connecting to said variable pressure system for feathering and unfeathering the propeller blades without interfering with the variable pressure system, said feathering system including a pressure storing means, means for charging said pressure storing means while the propeller is rotating but without affecting the variable pressure system in its change pitch requirements, a feathering control means for controlling the connection between the variable pressure system and the accumulator feathering system, said control means including a valve spring-urged normally to interrupt said connection, a mechanically restrained pilot valve for applying the charge of said pressure storing means to the said spring-urged valve for opening said connection, means for releasing the mechanical restraint of said pilot valve, and fluid pressure means made operable by movement of said spring-urged valve in opening said connection for returning the pilot valve to the restrained position.

9. In a fluid pressure system for controlling the blade pitch of a propeller, a variable pressure system including a pressure source, a fluid servomotor and distributor valve for shifting the pitch of the blades in either an increasing sense or a decreasing sense, for effecting constant speed operation of said propeller, selecting means for determining the speed level at which the distributor valve will effect shift of blade pitch, and for overriding the said distributor valve, an accumulator feathering system with means connecting to said variable pressure system for feathering and unfeathering the propeller blades without interfering with the variable pressure system, said feathering system including a pressure storing means, an independent pump and pressure control valve for charging the pressure storing means without affecting the variable pressure system while effecting constant speed operation, means selectively connecting the feathering system with the variable pressure system including a flow valve, a pilot valve having a set position and a released position, means for releasing the pilot valve from the set position coincident with overriding of the distributor valve by the selecting means, whereby the pilot valve moves to apply pressure from the storing means to the flow valve, and fluid pressure means responsive to said movement of the flow valve for resetting the pilot valve.

10. In a fluid pressure system of control for propeller blade pitch, a variable pressure system including a pressure source, a fluid servomotor, and distributor valve for shifting the pitch of the blades in either an increasing sense or in a decreasing sense, for effecting constant speed op-

eration of said propeller, selecting means for determining the speed level at which the distributor valve will effect shift of blade pitch, and for overriding the said distributor valve, an accumulator feathering system with means connecting to said variable pressure system for feathering and unfeathering the propeller blades without interfering with the variable pressure system, said feathering system including a pressure storing means, an independent pump and a pressure control valve for charging the pressure storing means without affecting the variable pressure system while effecting constant speed operation, means selectively connecting the feathering system with the variable pressure system including a flow valve, a pilot valve having a set position and a tripped position, means including the flow valve when the pilot valve is in the set position for blocking fluid connection between the feathering system and the variable pressure system, means operable when the pilot valve is in the tripped position for applying pressure to the flow valve for opening the said connection, and manually controlled means mechanically connected to the speed selecting means for releasing the pilot valve from its set position upon overriding of the distributor valve so that the stored pressure may be applied through said open connection to said variable pressure system for feathering and unfeathering as dictated by selective means override of the distributor valve.

11. In a variable pitch propeller, the combination including, a fluid pressure system for control of propeller pitch throughout its full range of governed pitch operation and feathered pitch operation, said system including a double acting fluid servomotor for adjusting propeller pitch, a first source of fluid pressure, a variable pressure control valve and a governor valve controlling the application of fluid pressure to said servomotor, manual means for adjusting said governor valve to select a speed level for governed pitch operation and to select feathered pitch operation, a second source of fluid pressure independent of said first pressure source, and valve means for connecting said second pressure source to said system for effecting feathered pitch operation when said first pressure source is depleted, said valve means including a pressure re-set trip valve actuated by said manual means when feathered pitch operation is selected.

12. The combination set forth in claim 11 wherein the second source of fluid pressure includes an accumulator and means for charging said accumulator, and said valve means includes a flow control valve actuated by accumulator pressure for connecting the accumulator to said system when the trip valve is actuated by the manual means.

13. In a variable pitch propeller, the combina-

tion including a fluid pressure system for control of propeller pitch throughout its full range of governed pitch operation and feathered pitch operation, said system including a fluid motor for adjusting propeller pitch, a first fluid pump, a variable pressure control valve and a distributor valve controlling fluid flow to and from said motor for effecting constant speed operation at any one of a plurality of selected speed levels, an accumulator, a second fluid pump for charging said accumulator, control valve means for connecting said accumulator with said system, said control valve means including a flow valve having two opposed faces, means applying the pressure of said system to one of said faces for normally maintaining the accumulator and the system disconnected, a pressure reset valve for applying accumulator pressure to the other of said faces, and resilient means allowing movement of said flow valve to a position connecting the accumulator with the system only when the potential of pressure in the accumulator is the higher.

14. In a fluid pressure controlled feathering propeller, the combination including, a first fluid pressure system for maintaining constant speed propeller operation, said first system including a first pressure developing means, a second fluid pressure system connectible with said first system for controlling feathering and unfeathering of the propeller, said second system including a second pressure developing means, passage means connecting the two systems, and a flow valve in the passage means normally exposed to the fluid pressure of said first system for blocking connection between said two systems.

15. The combination set forth in claim 14 wherein the second system includes a trippable pressure reset valve, and wherein said flow valve has opposite sides connectable to the first and second pressure systems, said reset valve normally blocking connection of the second system pressure with one side of the flow valve, means for tripping said reset valve to apply the pressure of said second system to said one side of the flow valve in opposition to the pressure of said first system acting on the other side of said flow valve for moving said flow valve to unblock the connection between said two systems.

RICHARD E. MOORE.
EDWARD W. LAPE.
OREN F. FLAUGH.

References Cited in the file of this patent

UNITED STATES PATENTS

Number	Name	Date
2,391,699	Haines et al. -----	Dec. 25, 1945
2,402,065	Martin -----	June 11, 1946
2,417,870	Haines -----	Mar. 25, 1947
2,424,749	Haines -----	July 29, 1947
2,505,206	Richardson et al. ----	Apr. 25, 1950